

# WICTEC 50 evo COLLECTION

## Sheer Variety of Design

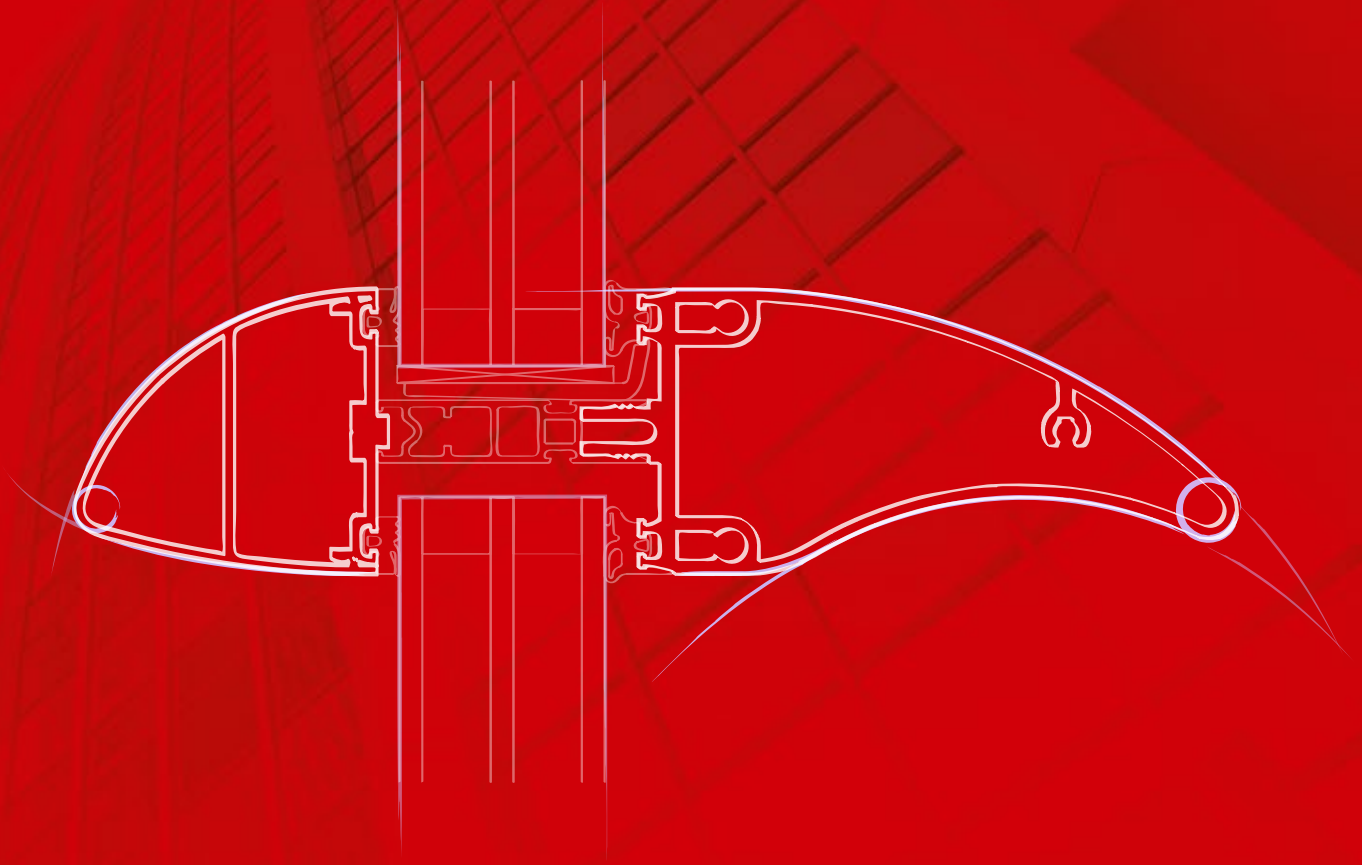

# » WICTEC 50 evo

## An evolution in façade technology

WICTEC 50 – the mullion-and-transom façade system from WICONA – has for decades been setting the standard in the design of the most challenging architecture worldwide. Now WICONA has further enhanced this „made in Germany“ technology.



# and design

## The result: WICTEC 50 evo

WICONA has successfully evolved its range of aluminium windows (WICLINE evo) and aluminium doors (WICSTYLE evo) in recent years. Thus, the evolution of the present WICTEC is the logical development step of the range of curtain walling solutions. This evolution now focuses on facades and the collaboration needed when “Building the city of the future together”.

WICTEC 50 evo enables planners and architects to satisfy the key challenges of modern urban architecture in a variety of ways:

- Sophisticated aesthetics, using a variety of profiles and colours to create a unique character
- Optimum energy efficiency by using, among other things, high solar gains
- Highest levels of user comfort by creating maximum natural light incidence and effective sun protection
- Harmonious integration of sound insulation, safety and fire protection components

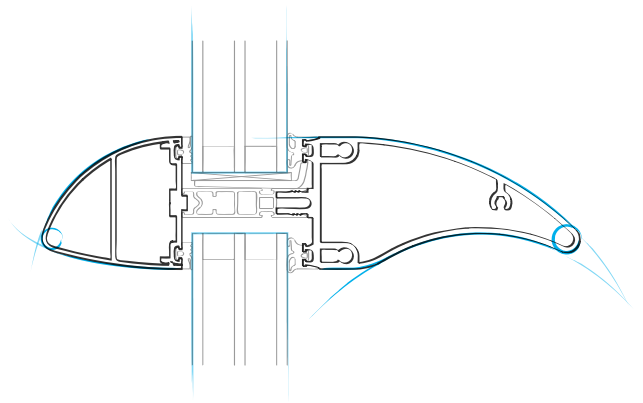

**Appealing  
aesthetic**



**Highest  
comfort**



**Utmost  
design freedom**



**Best possible  
energy efficiency**

# » WICTEC 50 evo COLLECTION

## Sheer variety of design

With the WICTEC 50 evo COLLECTION, the highlight of the WICTEC evolution, WICONA proves this: Façades do not always have to be angular. For planners and architects, this principle – literally speaking – opens up new dimensions and maximum freedom of design for the city of the future – both inside and outside.

The WICTEC 50 evo COLLECTION has been developed in collaboration with "Uli Schade Industriedesign" and "Bootschaft GbR" in Ulm. This collaboration is no accident. This metropolis on the Danube was formerly home to the Hochschule für Gestaltung (HfG, Design College). Today, it is still regarded as the most important Design College after the Bauhaus and was a pioneer as a model for later degree courses in design.



**The WICTEC 50 evo COLLECTION arose from this tradition – and stands for**

- Maximum design freedom on the façade – both inside and outside
- Façade design can be easily adapted according to the use of the building
- Interior design can be individually expressed and updated
- Eyecatching exterior façade due to its innovative appearance
- Possibility to create stark contrast or harmonious integration with surrounding developments



## » WICTEC 50 evo COLLECTION

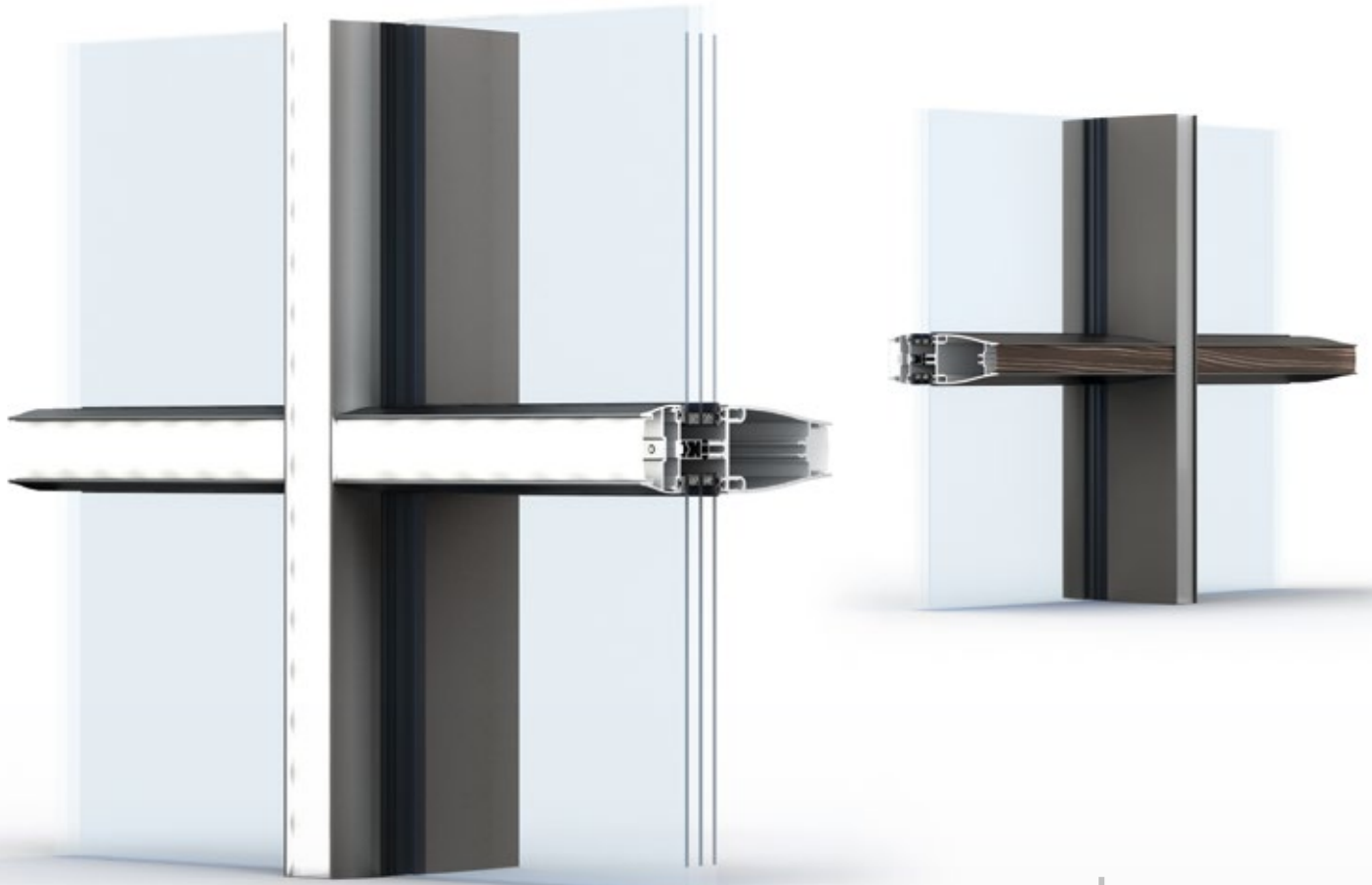

varivex

Besides the six different profile shapes, the WICTEC 50 evo COLLECTION offers the option to customise, with additional components such as:

- Different profile colours
- Integrated LED lighting strips and different colours of lights
- Integration of panels (e.g. wood)

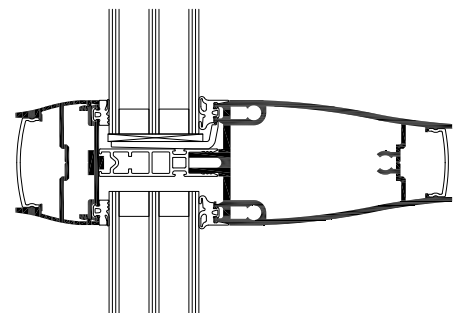
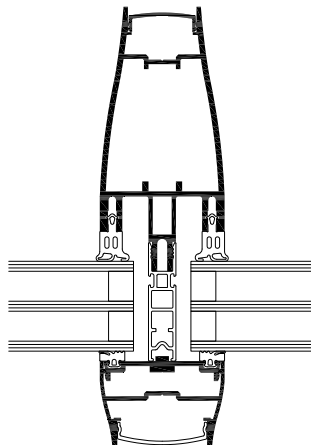

» WICTEC 50 evo COLLECTION

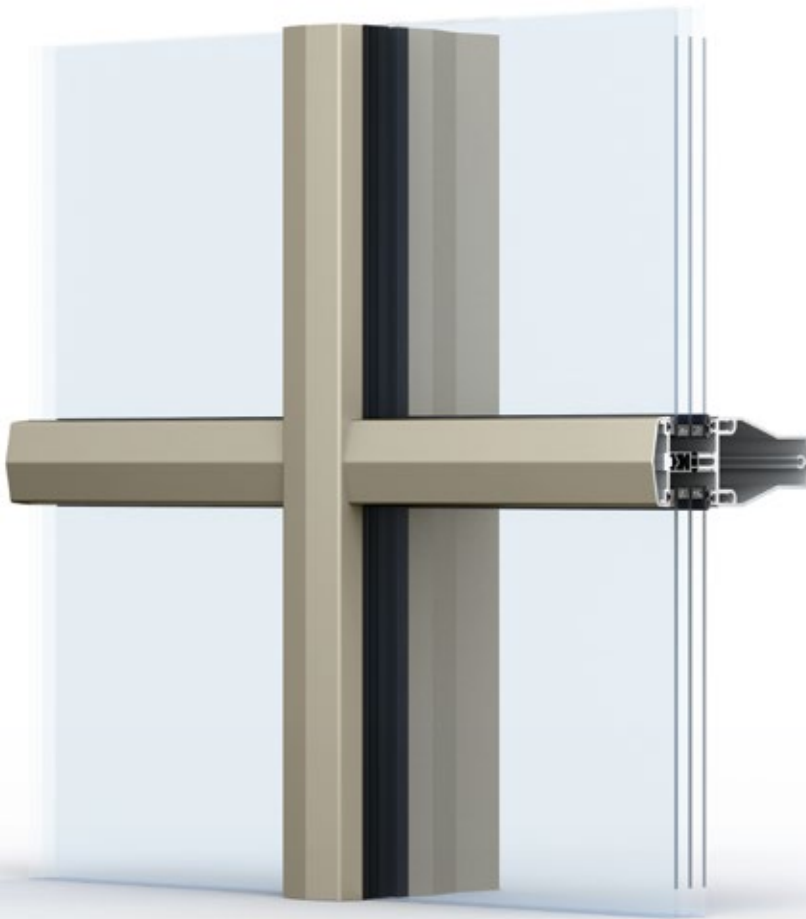

kobita

Thanks to WICONA's innovative approach, architects, planners and developers can achieve attractive design solutions for innovative façades, which will lend many cities a modern "face" in the future.

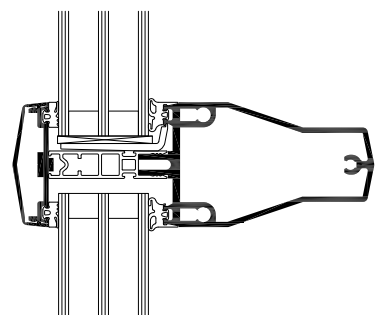
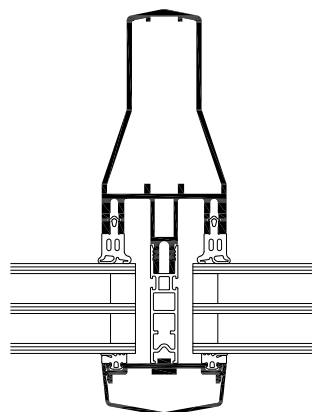

» WICTEC 50 evo COLLECTION

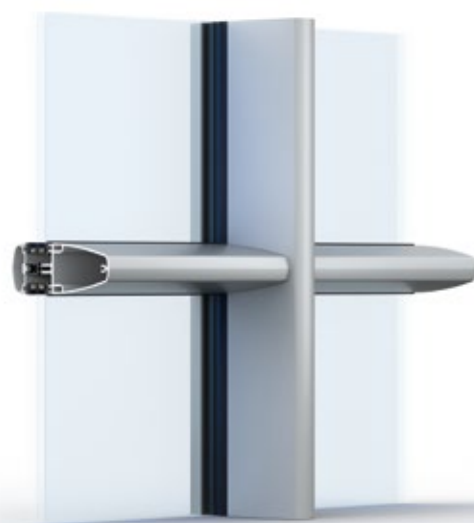
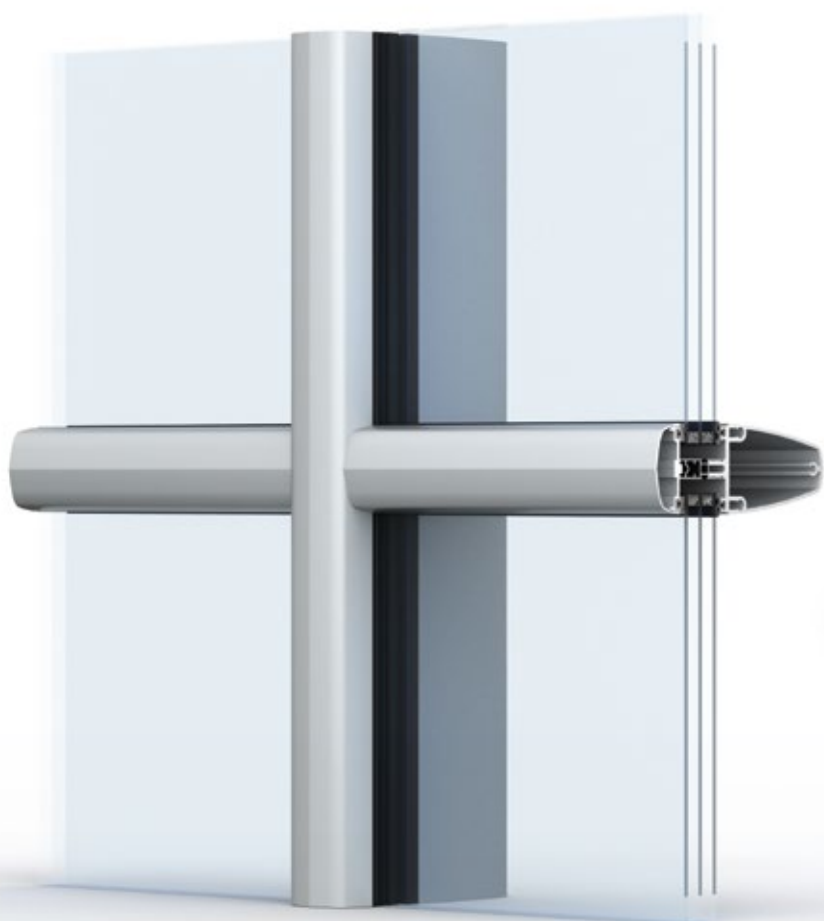

squara

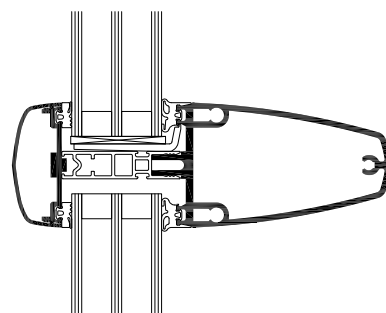
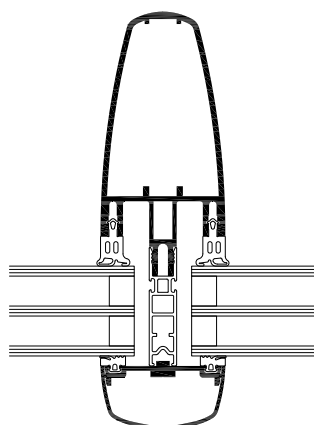



» WICTEC 50 evo COLLECTION

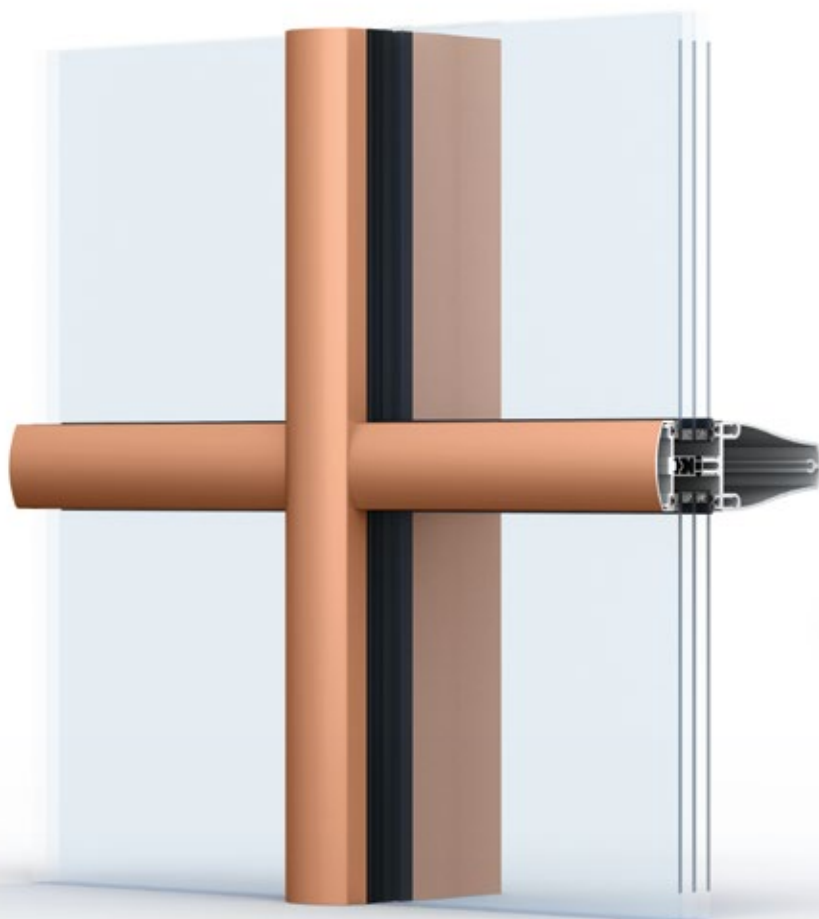

tanqua

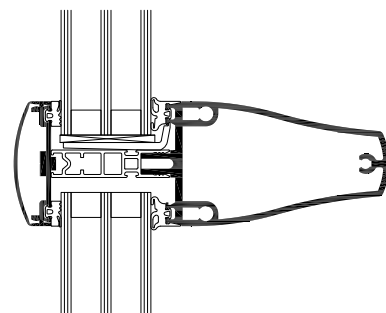
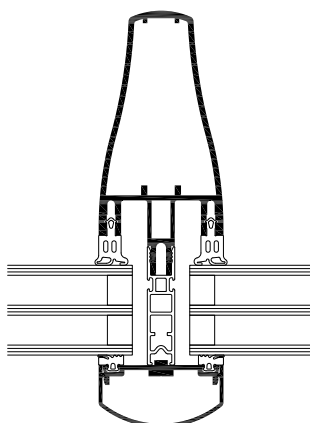

» WICTEC 50 evo COLLECTION



trita

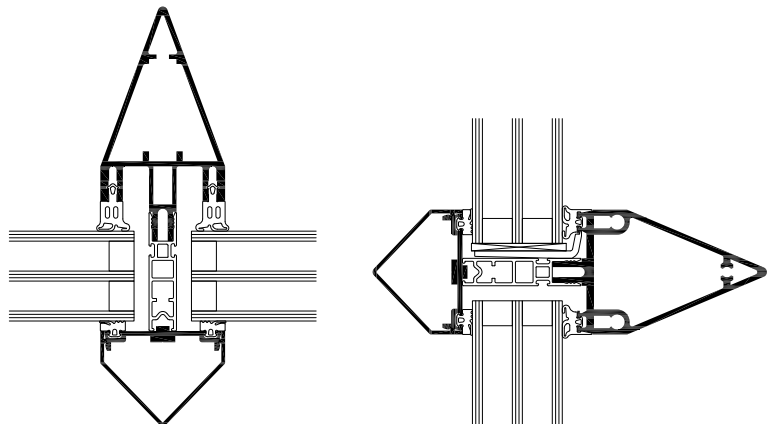

» WICTEC 50 evo COLLECTION



aerovex

WICTEC 50 evo COLLECTION  
– a façade system that will  
change how our future cities  
will look...

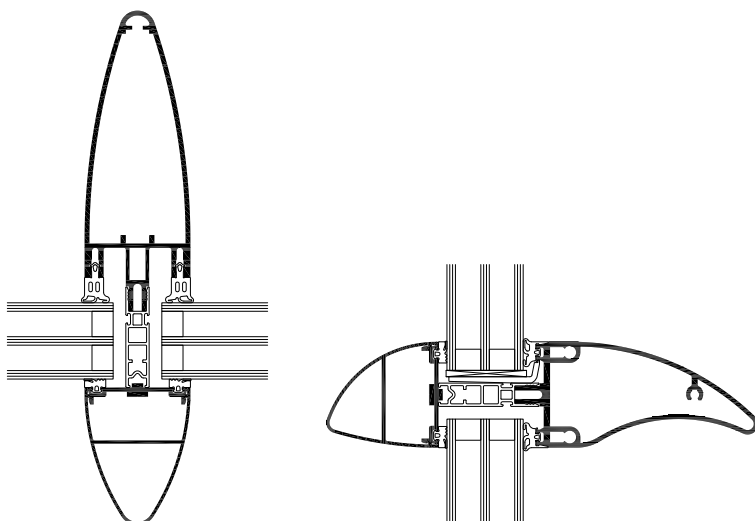

# » Maximum freedom of design

## Profiles

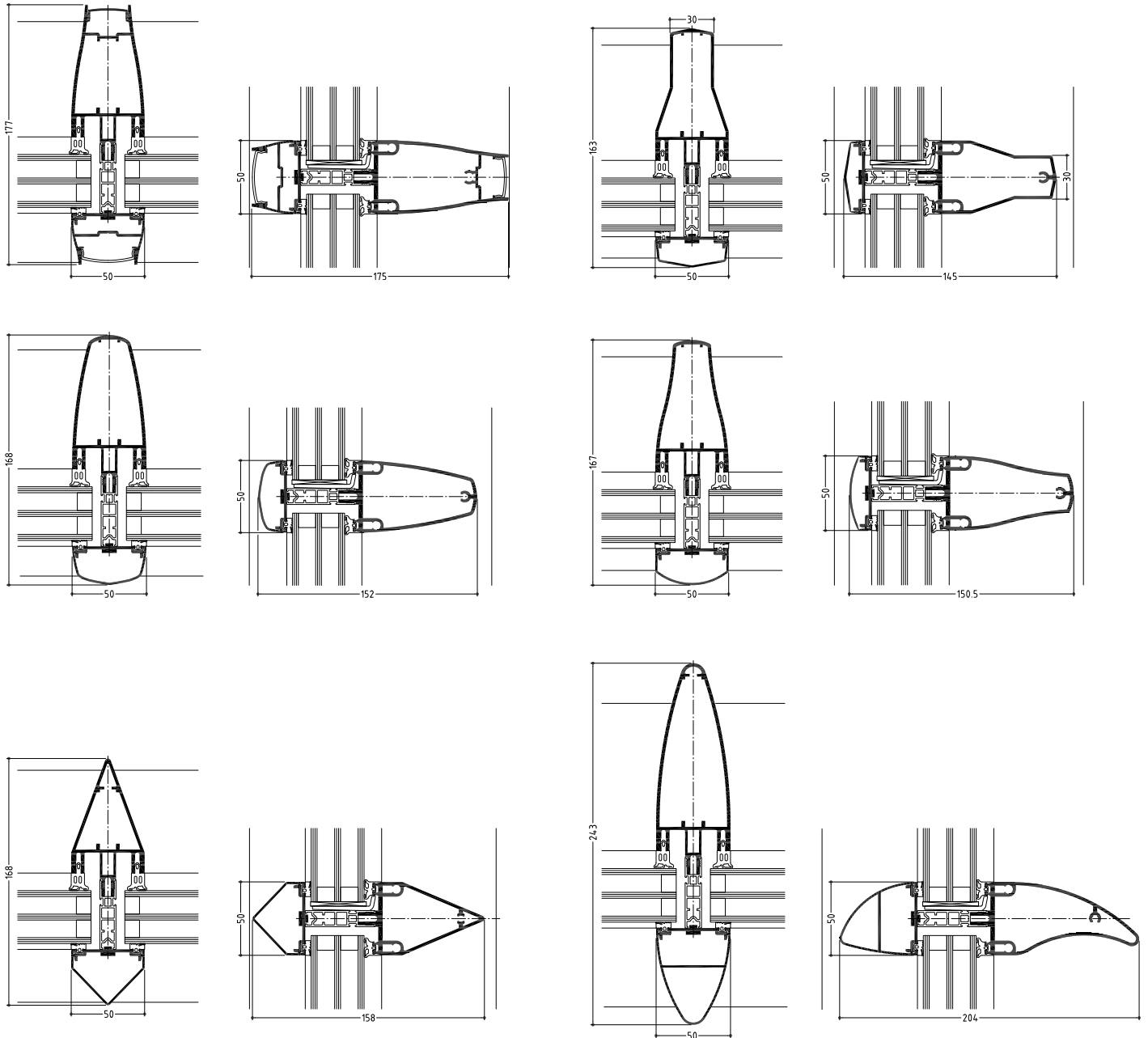

## The City of the Future is wearing colour...

Modern city architecture thrives on attractive building shapes and colours. Building the city of the future also means adding colour, emphasising the individual design of the building's structure, creating a contrast with its surroundings or complementing it with a coherent appearance.

With this special colour programme, WICONA is addressing requirements as they occur in the city of the future: with solutions that urban architects can bring to life, both visually and functionally, for the user.

# » Cradle 2 Cradle

## Sustainable and ecological

At WICONA, sustainability and ecology have been a fundamental part of the company's philosophy for a long time. Recently, this was significant with them being awarded the Bronze Cradle-to-Cradle (C2C) Certificate for, among other things, the WICTEC 50 façades.

- The process leading to certification takes the designer and manufacturer through a process of continuous product optimisation towards a combination of ambitious aesthetics, technical quality and the highest ecological standards.
- The C2C Certificate complements and also offers an alternative to the well-known building certificates (DGNB, LEED, BREEAM, etc.) The criteria are directly related to the product, not to the entire building. The responsibility of the product manufacturer, including the entire prefabrication and supply chain, comes into focus.
- In order to achieve one of the five levels of certification (from Basic up to Platinum), a product must satisfy the minimum requirements of the relevant level in the following five categories: Material health, Material reutilization, Renewable energy and carbon management, Water stewardship and Social fairness and biodiversity

The five C2C categories enable all aspects of the materials used, the manufacturing process – including the company's social responsibility and its impact for society – to be considered throughout the certification process.

For planners and architects, certification provides them with the advantage that, with WICONA aluminium systems, they are always able to automatically achieve at least C2C Bronze Standard. However, for WICONA, this standard is just the start of their journey towards Platinum level.



Fotograf: Hufton+Crow

# » Let's build together the city of the future

Since 2008, says the United Nations, 50% of the world's population lives in towns and cities, some of which have grown to megalopolis proportions in just a few decades; 36 of them are now home to more than 10 million inhabitants.

In 2020, 80% of Europeans will be living in urban areas. By 2050, two-thirds (namely 70%) of those living on our planet will be city-dwellers. 2050 is only just around the corner.

That new population density presents us with a huge challenge to overcome - how can we live together successfully under such conditions? - but other factors also have a direct influence on the highly complex system we call "the city". Climate change, depletion of natural resources, starting with fossil fuels and water, decreasing availability of building land, the digital revolution, new ways of living... All represent constraints and opportunities, and force us to re-think our cities. Most importantly, we need to establish and reinvent how we relate to the city, and more than anything, how we relate to one another. How we relate to a new type of urbanism.

There is a new order, and a wealth of possible solutions. For a number of years now, many people have been imagining an intelligent,

interactive city - the "connected" or smart city - which adapts to our needs through new technologies, particularly information and communication (NICTs). Our world is like a huge experimental laboratory, with new ways of doing things and new urban development models springing up all over the place. They all point towards a resolutely more "sustainable" city, where economic, social and ecological aspects combine seamlessly around key objectives: a sensible use of resources, putting citizen-users at the heart of planning, a systemic approach to the city.

The city of tomorrow is re-envisioned in terms of "function", and offers a cross-wise, decompartmentalised view of urbanism, rather than the top-down approach. This means it is better to talk of "urbanisms" in the plural. The new city, as a real "ecosystem", needs to adapt to where it develops on the globe, as necessitated by the varying climatic conditions. The architecture itself must also fit in with those constraints, just as it needs to respond to the requirements set by the new city's new key player: the citizen-user. The arrival of new generations - led by the "Millennium generation", the famous "Generation Y" - puts collective intelligence and cross-fertilisation in the spotlight.



The “co” age is upon us: collaboration, cooperation, cocreation, community, underpinned by innovative forms of joint venture and city design, with all stakeholders playing their part.

Against that backdrop, what architecture will tomorrow bring? Although it seems to be generally accepted that the architecture of the future will see a balance between man-made engineering and all of nature’s science and ingenuity, the issue has swept aside all the traditional approaches to design and planning. Building Information Modelling (BIM) has already started to revolutionise the way in which buildings, infrastructure and technical networks are planned, designed, created and managed. Other emerging trends will progressively have an influence, each providing new opportunities:

the circular economy, urban agriculture, bionics, biomimetics and biomorphism, smart grids etc.

When that happens, designing the buildings of tomorrow will prove to be both a real challenge and a fascinating endeavour.

**We are ready for that!**

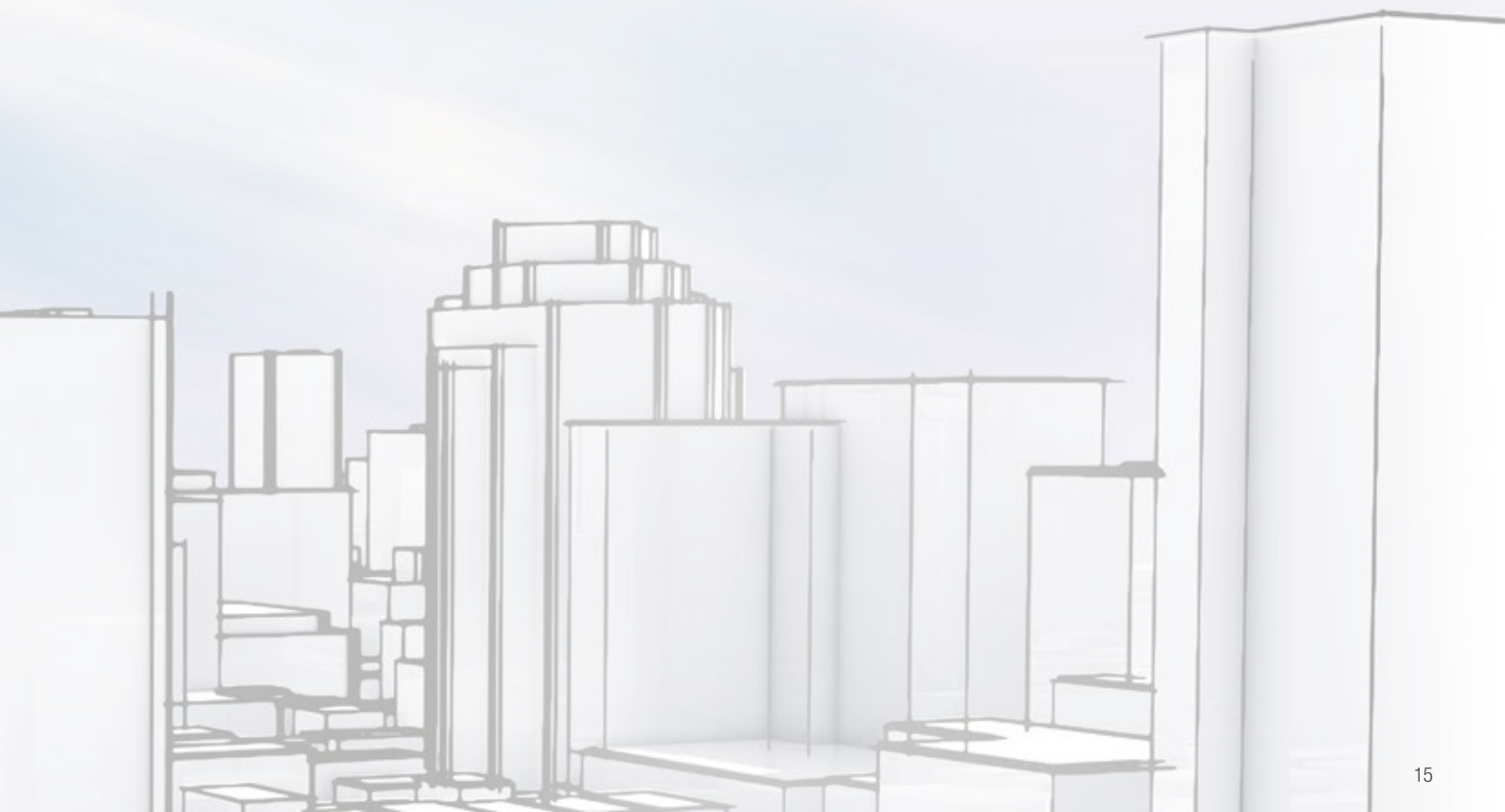

**Austria**

5201 Seekirchen  
☎ +43 6212 2000  
✉ info@wicona.at

**Benelux**

3400 Landen  
☎ +32 11 690316  
✉ info@wicona.be  
✉ info@wicona.nl

**Croatia**

43000 Bjelovar  
☎ +385 43 22 25 46  
✉ info@wicona.de

**Czech Republic**

15500 Praha  
☎ +420 721 333 133  
✉ wicona@wicona.cz

**Denmark**

8240 Risskov  
☎ +45 7020 2048  
✉ wicona@wicona.dk

**España**

08195 Sant Cugat del Vallès  
Barcelona  
☎ +34 93 573 77 76  
✉ wicona.es@wicona.com

**Estonia / Latvia**

11317, Tallinn  
☎ +37 2657 6635  
✉ info@wicona.ee

**France**

02200 Courmelles  
☎ +33 3 23598200  
✉ info@wicona.fr

**Germany**

89077 Ulm  
☎ +49 731 3984-0  
✉ info@wicona.de

**Hungary**

1031 Budapest  
☎ +36 (1) 4533457  
✉ info@wicona.hu

**Ireland**

Dublin 22  
☎ +353 1 4105766  
✉ info@wicona.ie

**Italia**

20063 Cernusco sul Naviglio MI  
☎ +39 02 924291  
✉ info@wicona.it

**Lithuania / Latvia**

02244, Vilnius  
☎ +370 5 2102587  
✉ info@wicona.lt

**Norway**

2007 Kjeller  
☎ +47 22 422200  
✉ wicona@wicona.no

**Poland**

03-828 Warszawa  
☎ +48 22 3308170  
✉ info@wicona.pl

**Romania**

031041 Bucharest  
☎ +40 21 3260045  
✉ info@wicona.de

**Serbia**

11070 Beograd  
☎ +381 11 312 18 35  
✉ info@wicona.de

**Slovakia**

821 08 Bratislava  
☎ +421 918 725 098  
✉ wicona@wicona.sk

**Slovenia**

2201 Zg. Kungota  
☎ +386 26 20 99 70  
✉ info@wicona.de

**Sweden**

574 81 Vetlanda  
☎ +46 470 787400  
✉ wicona@wicona.se

**Switzerland**

5506 Mägenwil  
☎ +41 62 88741-41  
✉ info@wicona.ch

**United Kingdom**

Wakefield WF5 9TG  
☎ +44 1924 232323  
✉ info.wiconauk@wicona.com

**China**

Beijing 100005, P.R.C  
☎ +86 10 6059 5686 ext. 805  
✉ contact.wicona.international@wicona.com

**Singapore**

608831 Singapore  
☎ +65 6513 2126  
✉ contact.wicona.international@wicona.com

**United Arab Emirates**

**Dubai**  
☎ +971 4 887 00 96  
✉ contact.wicona.international@wicona.com

**Other countries**

31037 Toulouse  
☎ +33 5 61312626  
✉ contact.wicona.international@wicona.com

