

WICTEC 50 evo

Evolution in façade technology



© Saint-Gobain / Fotograf: Carl Roth/Arcahan

Aluminium façades



» WICTEC 50 evo

An evolution in façade technology and design

“Building the city of the future together” – this guiding principle represents the collaborative partnership between WICONA, planners, architects and customers of façades and metalwork. Common experience on many projects worldwide has shown that challenging building projects can be successfully completed when the process is based on an integrated approach from all stakeholders.

With the latest step in its development of WICTEC 50 evo, WICONA has created favourable preconditions for this in the area of façades.

WICTEC 50 – the mullion-and-transom façade system from WICONA – has for decades been setting the standard in the design of the most challenging architecture worldwide. Now WICONA has further enhanced this “Made in Germany” technology.

The result: WICTEC 50 evo

WICONA has successfully evolved its range of aluminium windows (WICLINE evo) and aluminium doors (WICSTYLE evo) in recent years. Thus, the evolution of the present WICTEC is the logical development step of the range of curtain walling solutions.



WICTEC 50 evo enables planners and architects to satisfy the key challenges of modern urban architecture in a variety of ways:

- Sophisticated aesthetics, using a variety of profiles and colours to create a unique character
- Optimum energy efficiency by using, among other things, high solar gains
- Highest levels of user comfort by creating maximum natural light incidence and effective sun protection
- Harmonious integration of soundproofing, security and fire protection components

Façade installer and fabricators benefit from the WICTEC 50 evo façade's

- Innovative product details with their unique selling points
- High process reliability
- Time-saving installation steps
- Flexibility in its production
- Price savings which can be passed on to the end customer

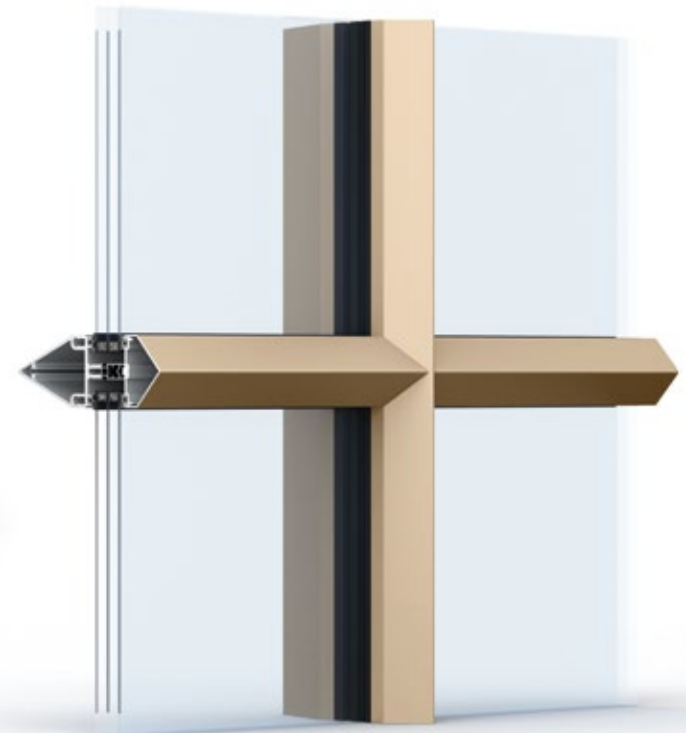

**Appealing
aesthetic**



**Highest
comfort**



**Utmost
design freedom**



**Process friendly
and excellent quality**

» Design and technology

WICTEC 50 evo Collection

With WICTEC 50 evo COLLECTION, the highlight of the WICTEC evolution, WICONA proves this: Façades do not always have to be angular. This therefore opens up new dimensions and maximum freedom of design for the city of the future – both inside and outside.

The WICTEC 50 evo COLLECTION has been developed in collaboration with “Uli Schade Industriedesign” and “Bootschaft GbR” in Ulm. This metropolis on the Danube was formerly home to the Hochschule für Gestaltung (Ulm Design College). Today, it is still regarded as the most important Design College after the Bauhaus and was a pioneer as a model for later degree courses in design.

The WICTEC 50 evo COLLECTION arose from this tradition – and stands for

- Maximum design freedom on the façade – both inside and outside
- Façade design can be easily adapted according to the use of the building
- Interior design can be individually expressed and updated
- Eyecatching exterior façade due to its innovative appearance
- Possibility to create stark contrast or harmonious integration with surrounding developments



varivex

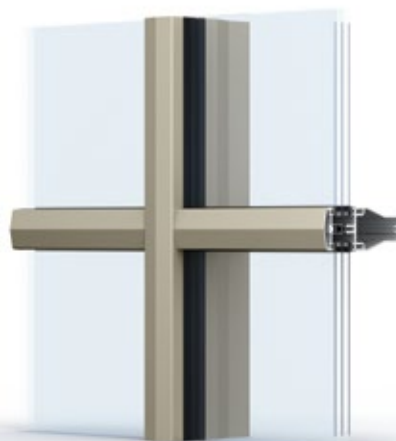

kobita



squara

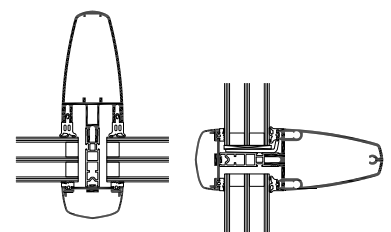
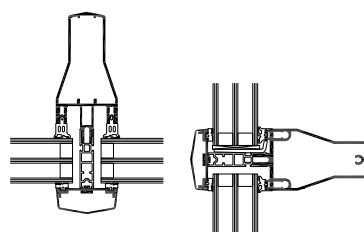
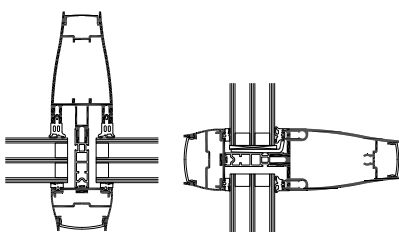



tanqua

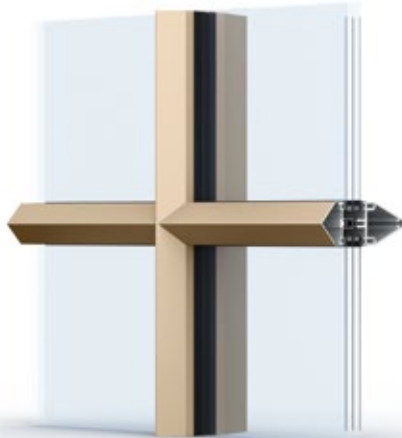

trita



aerovex

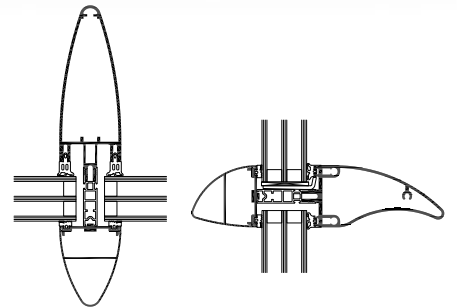
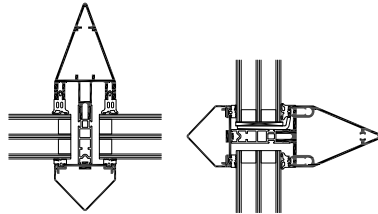
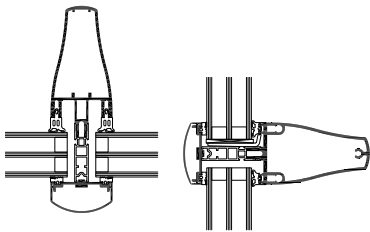

Besides the six different profile shapes, the WICTEC 50 evo COLLECTION offers the option to customise, with additional components such as

- Different profile colours
- Integrated LED lighting strips and different colours of lights
- Integration of panels (e.g. wood)



Appealing aesthetic



Highest comfort



Utmost design freedom



Best possible energy efficiency



Foto: Gilles Bertrand



Heavy load system

In modern architecture, especially in the cities of the future, glass is one of the fundamental characteristics of the façade design. High proportions of glass not only provide fascinating visual accents and distinctive natural light incidence, but also achieve other benefits, such as passive energy gains from the sun. The trend is increasingly towards larger glazed areas within the façade which must be held stable and secure as part of the construction.

To fulfil the architectural requirements for maximising transparent surface areas, WICONA offers a new high load system as part of its WICTEC 50 evo range.

It can accommodate a maximum glass weight of up to 150 kg compared with the existing WICTEC 50 façade. That allows for a maximum glass weight of up to 550 kg with a slim sight line of just 50 mm.

Technical details

- WICONA has commissioned elaborate finite element calculations, in order to upgrade only those places where it is economically viable.
- This optimisation is achieved without any significant increase in the number of components: The performance of the WICTEC 50 can be sustainably improved by introducing just two new accessories into the range.
- WICONA has paid particular attention to quick and easy installation.
- Even costs have been kept manageable: Compared to the effect achieved by maximising the weight of glass, the additional costs for the installer are only slightly higher than in the standard application.
- Also new is the fact that this system does not have any of the load restrictions associated with retrofitted connectors. So even when transom joints are retrofitted on site, the same infill weights can be transferred.

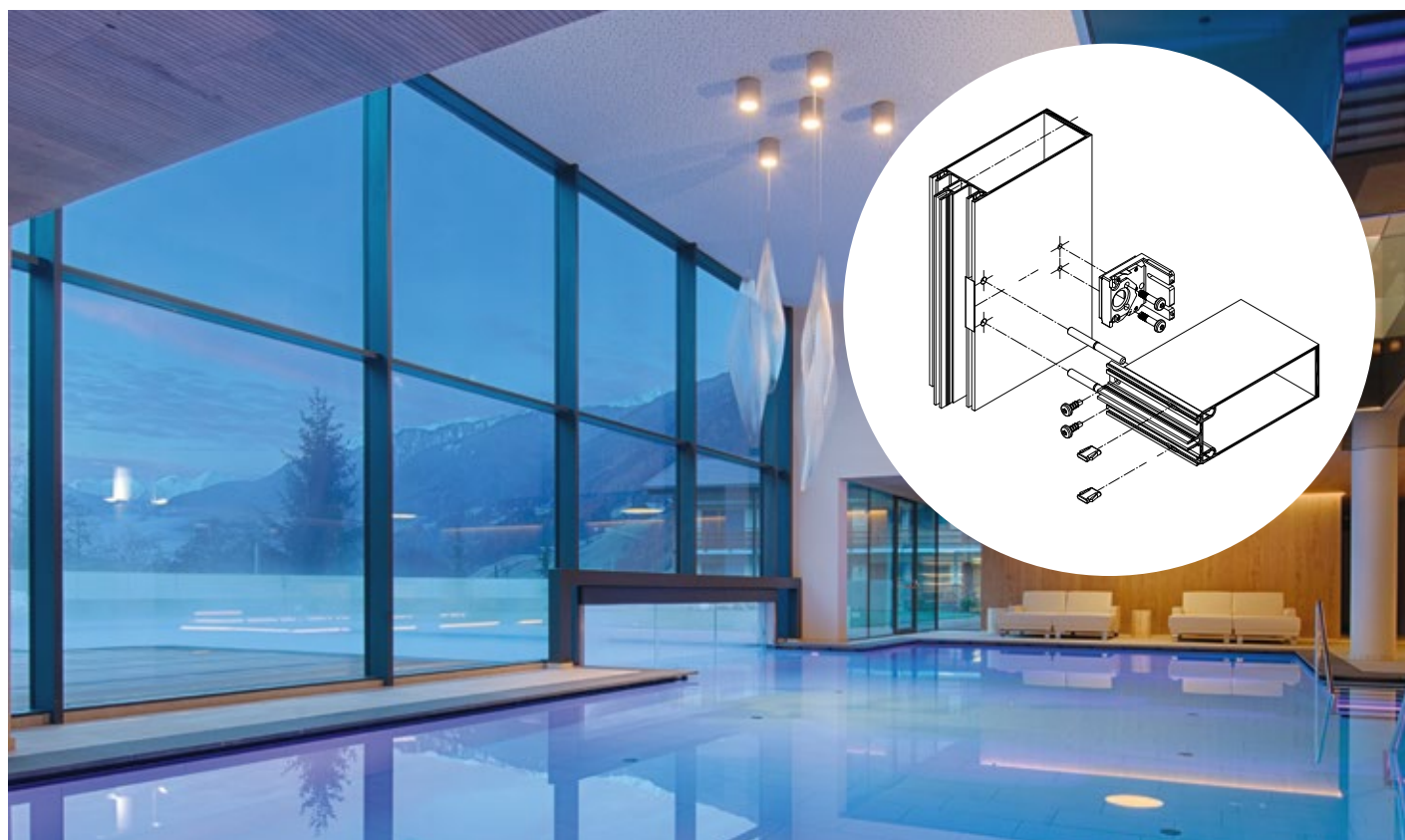

Quick glazing using partial pressure holders

Easier, quicker and more cost-effective – glazing mullion-and-transom façades using the new quick-glazing system using partial pressure holders is a real innovation from WICONA. They enable linear glazing to be installed with short pieces and spare the fabricators the usual processing steps of continuous press strip assembly.



Technical details

- Installation is as normal:
 - position the glazing
 - fix the glass using the short pieces or the new pressure holders
 - installation of the continuous glazing strip is not necessary
 - once the glazing is fixed using the pressure holders, the decorative cover strip can be fitted directly
- For the installer, this results in significant time savings on site
- There are no additional material costs compared with conventional WICTEC 50 façades; instead, façade installation costs are saved
- The WICTEC 50's excellent performance characteristics are completely maintained
- The system can be used with the new straight cut technology and can also be combined with the conventional notched cut technology

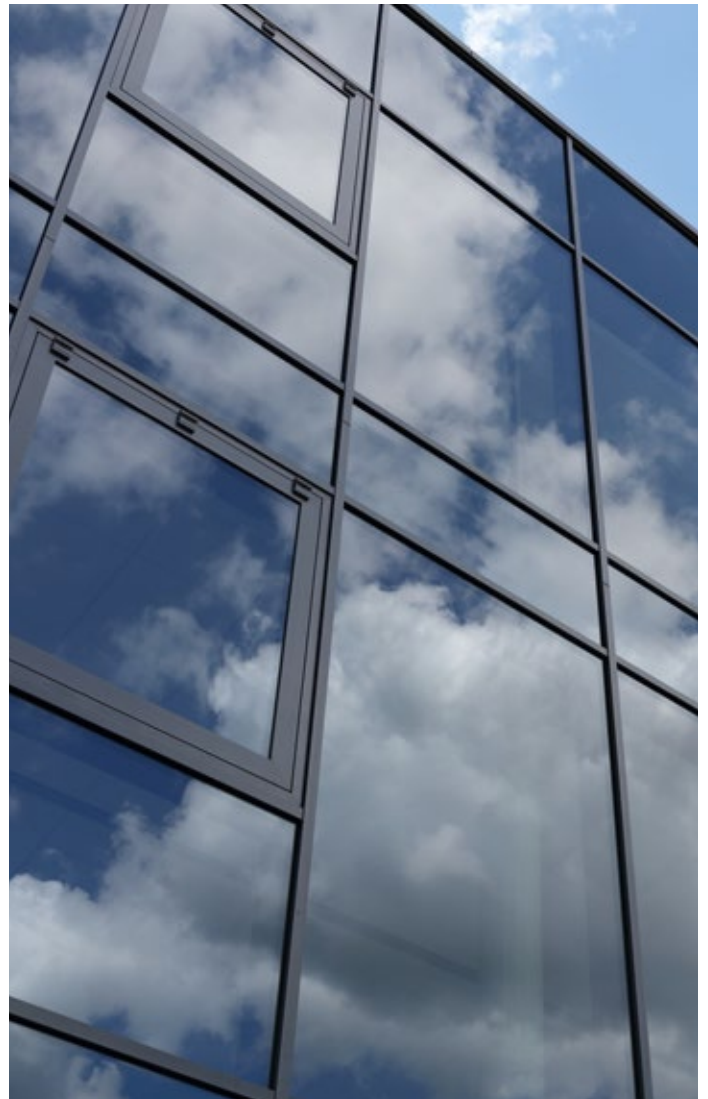

**Innovation
made by WICONA**



**Time saving
on site**



**Cost savings for
façade installation**

Straight cut

This innovation is an economical solution for reliable and quick implementation of small to medium façade projects, especially for

façade bands and set façades with a picture-frame appearance, or shop fronts.

Technical details

- Optional design with mullion or mullion-and-transom façades with straight cut and profiles without notched milling
- Moulded parts replace the notched cut
- New connectors are used, with “1-screw installation” to the mullion
- Transom screw joints are made using self-sealing screws
- The same levels of performance in terms of joint permeability and driving rain resistance as those of the existing WICTEC 50
- New retrofit connectors with disconnection function



Simplified structural attachments

This area of façades is technically particularly sensitive. The execution of the transition to the building structure must be expertly and carefully carried out. WICONA facilitates this process with the evolution

of the WICTEC 50 façades by using innovative components which make the process of connection to the building structure as well as to clamping elements such as doors safe and reliable for the installer.

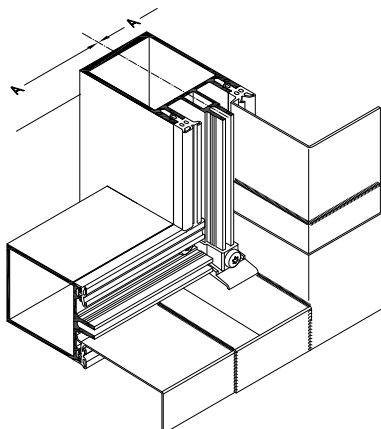
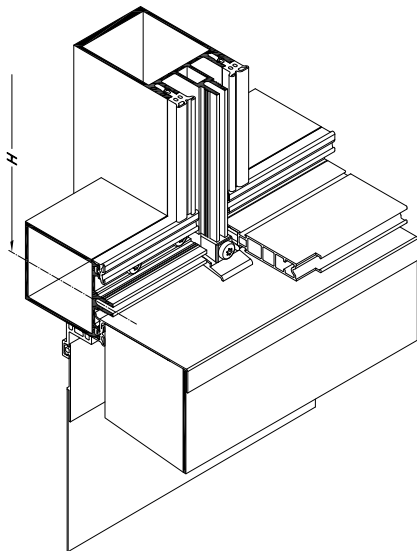
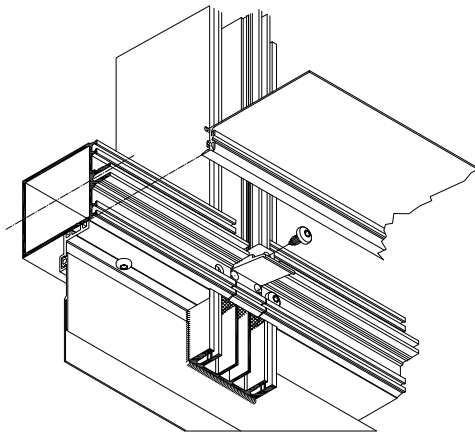

Technical details

- A new central drainage component enables the lower transom seal to be installed as a continuous piece, which allows, for example, cover plates to be seamlessly fixed into the structure.
- A new type of mullion-and-transom seal with an extruded foil flange enables a continuous overlap of the cover plates or panels in the connection area
- Moulded parts enable a controlled connection to clamping elements such as doors and allow for a trough-shaped formation of the lower and upper corner points of the façade.



» Cradle 2 Cradle

Sustainable and ecological

From now on, these products will not only be valued for their aesthetics and functionality, but also for their effect on the environment, on health and for their suitability for the material cycle.

At WICONA, sustainability and ecology have been a fundamental part of the company's philosophy for a long time. Recently, this was significant with them being awarded the Bronze Cradle-to-Cradle (C2C) Certificate for, among other things, the WICTEC 50 façades.

- The process leading to certification takes the designer and manufacturer through a process of continuous product optimisation towards a combination of ambitious aesthetics, technical quality and the highest ecological standards.
- The C2C Certificate complements and also offers an alternative to the well-known building certificates (DGNB, LEED, BREEAM, etc.) The criteria are directly related to the product, not to the entire building. The responsibility of the product manufacturer, including the entire prefabrication and supply chain, comes into focus.
- In order to achieve one of the five levels of certification (from Basic up to Platinum), a product must satisfy the minimum requirements of the relevant level in the following five categories: Material health, Material reutilization, Renewable energy and carbon management, Water stewardship and Social fairness and biodiversity

The five C2C categories enable all aspects of the materials used, the manufacturing process – including the company's social responsibility and its impact for society – to be considered throughout the certification process.

For planners and architects, certification provides them with the advantage that, with WICONA aluminium systems, they are always able to automatically achieve at least C2C Bronze Standard. The differences in their ecological thinking and behaviour compared to the competition are clearly visible. However, for WICONA, the Bronze standard is just the start of their journey towards Platinum level.



Fotograf: Hufton+Crow



» Let's build together the city of the future

Since 2008, says the United Nations, 50% of the world's population lives in towns and cities, some of which have grown to megalopolis proportions in just a few decades; 36 of them are now home to more than 10 million inhabitants.

In 2020, 80% of Europeans will be living in urban areas. By 2050, two-thirds (namely 70%) of those living on our planet will be city-dwellers. 2050 is only just around the corner.

That new population density presents us with a huge challenge to overcome - how can we live together successfully under such conditions? - but other factors also have a direct influence on the highly complex system we call "the city". Climate change, depletion of natural resources, starting with fossil fuels and water, decreasing availability of building land, the digital revolution, new ways of living... All represent constraints and opportunities, and force us to re-think our cities. Most importantly, we need to establish and reinvent how we relate to the city, and more than anything, how we relate to one another. How we relate to a new type of urbanism.

There is a new order, and a wealth of possible solutions. For a number of years now, many people have been imagining an intelligent,

interactive city - the "connected" or smart city - which adapts to our needs through new technologies, particularly information and communication (NICTs). Our world is like a huge experimental laboratory, with new ways of doing things and new urban development models springing up all over the place. They all point towards a resolutely more "sustainable" city, where economic, social and ecological aspects combine seamlessly around key objectives: a sensible use of resources, putting citizen-users at the heart of planning, a systemic approach to the city.

The city of tomorrow is re-envisioned in terms of "function", and offers a cross-wise, decompartmentalised view of urbanism, rather than the top-down approach. This means it is better to talk of "urbanisms" in the plural. The new city, as a real "ecosystem", needs to adapt to where it develops on the globe, as necessitated by the varying climatic conditions. The architecture itself must also fit in with those constraints, just as it needs to respond to the requirements set by the new city's new key player: the citizen-user. The arrival of new generations - led by the "Millennium generation", the famous "Generation Y" - puts collective intelligence and cross-fertilisation in the spotlight.



The “co” age is upon us: collaboration, cooperation, cocreation, community, underpinned by innovative forms of joint venture and city design, with all stakeholders playing their part.

Against that backdrop, what architecture will tomorrow bring? Although it seems to be generally accepted that the architecture of the future will see a balance between man-made engineering and all of nature’s science and ingenuity, the issue has swept aside all the traditional approaches to design and planning. Building Information Modelling (BIM) has already started to revolutionise the way in which buildings, infrastructure and technical networks are planned, designed, created and managed. Other emerging trends will progressively have an influence, each providing new opportunities:

the circular economy, urban agriculture, bionics, biomimetics and biomorphism, smart grids etc.

When that happens, designing the buildings of tomorrow will prove to be both a real challenge and a fascinating endeavour.

We are ready for that!

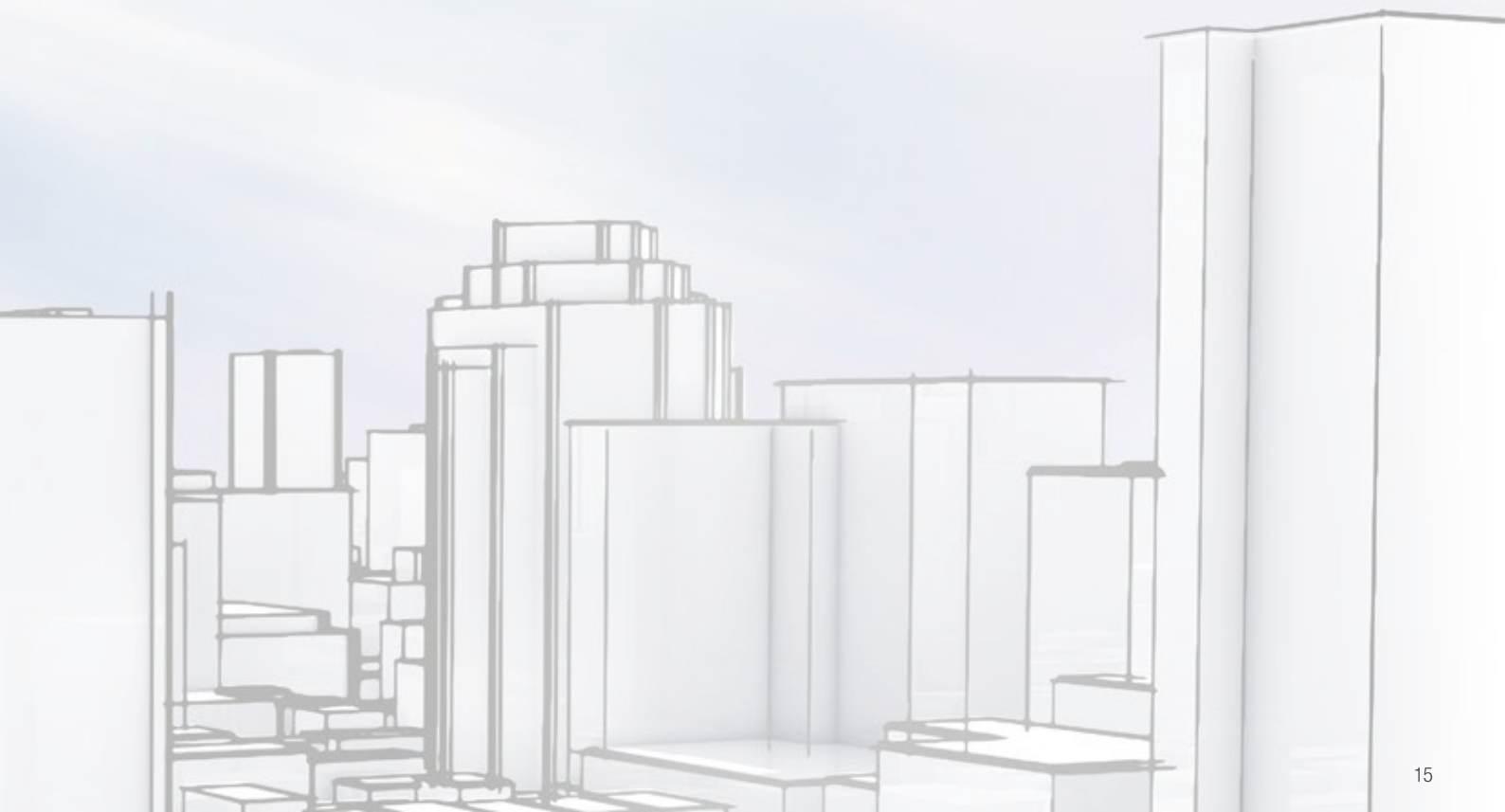

Austria

5201 Seekirchen
☎ +43 6212 2000
✉ info@wicona.at

Benelux

3400 Landen
☎ +32 11 690316
✉ info@wicona.be
✉ info@wicona.nl

Croatia

43000 Bjelovar
☎ +385 43 22 25 46
✉ info@wicona.de

Czech Republic

15500 Praha
☎ +420 721 333 133
✉ wicona@wicona.cz

Denmark

8240 Risskov
☎ +45 7020 2048
✉ wicona@wicona.dk

España

08195 Sant Cugat del Vallès
Barcelona
☎ +34 93 573 77 76
✉ wicona.es@wicona.com

Estonia / Latvia

11317, Tallinn
☎ +37 2657 6635
✉ info@wicona.ee

France

02200 Courmelles
☎ +33 3 23598200
✉ info@wicona.fr

Germany

89077 Ulm
☎ +49 731 3984-0
✉ info@wicona.de

Hungary

1031 Budapest
☎ +36 (1) 4533457
✉ info@wicona.hu

Ireland

Dublin 22
☎ +353 1 4105766
✉ info@wicona.ie

Italia

20063 Cernusco sul Naviglio MI
☎ +39 02 924291
✉ info@wicona.it

Lithuania / Latvia

02244, Vilnius
☎ +370 5 2102587
✉ info@wicona.lt

Norway

2007 Kjeller
☎ +47 22 422200
✉ wicona@wicona.no

Poland

03-828 Warszawa
☎ +48 22 3308170
✉ info@wicona.pl

Romania

031041 Bucharest
☎ +40 21 3260045
✉ info@wicona.de

Serbia

11070 Beograd
☎ +381 11 312 18 35
✉ info@wicona.de

Slovakia

821 08 Bratislava
☎ +421 918 725 098
✉ wicona@wicona.sk

Slovenia

2201 Zg. Kungota
☎ +386 26 20 99 70
✉ info@wicona.de

Sweden

574 81 Vetlanda
☎ +46 470 787400
✉ wicona@wicona.se

Switzerland

5506 Mägenwil
☎ +41 62 88741-41
✉ info@wicona.ch

United Kingdom

Wakefield WF5 9TG
☎ +44 1924 232323
✉ info.wiconauk@wicona.com

China

Beijing 100005, P.R.C
☎ +86 10 6059 5686 ext. 805
✉ contact.wicona.international@wicona.com

Singapore

608831 Singapore
☎ +65 6513 2126
✉ contact.wicona.international@wicona.com

United Arab Emirates

Dubai
☎ +971 4 887 00 96
✉ contact.wicona.international@wicona.com

Other countries

31037 Toulouse
☎ +33 5 61312626
✉ contact.wicona.international@wicona.com

